

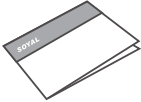



Contents

AR-321H [Touch-panel Metal Housing]



- 1 Product 
- 2 User Guide 
- 3 Terminal Cables 
- 4 Tools 
- 5 Water proof Strip 

AR-331H [Touch-panel Metal Housing]/ AR-331H-S [Metal Housing]

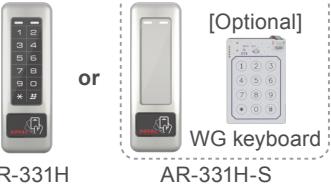
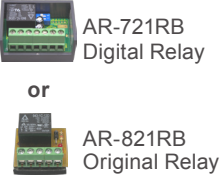
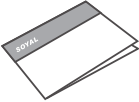
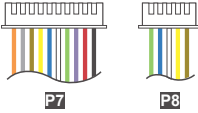
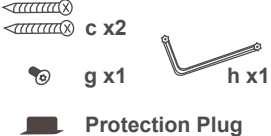
※ Must to purchase relay

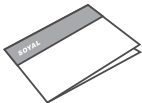

- 1 Product 
- 2 Optional 
- 3 User Guide 
- 4 Terminal Cables 
- 5 Tools 

AR-721H

- 1 Product 
- 2 User Guide 
- 3 Terminal Cables 
- 4 Tools 

AR-725H [Illuminated Touch-panel]

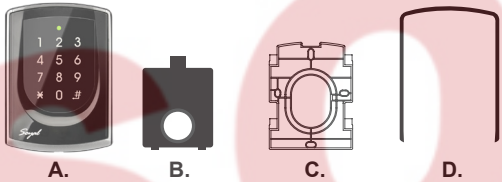
AR-725H-M

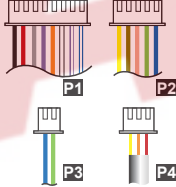
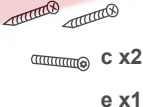
- 1 Products 
- 2 User Guide 
- 3 Terminal Cables 
- 4 Tools 

AR-725H

- 1 Products 
- 2 User Guide 
- 3 Terminal Cables 
- 4 Tools 



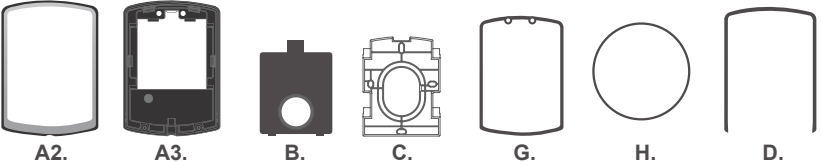
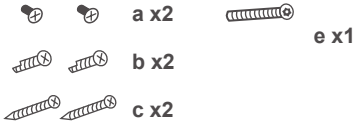





AR-725X

- 1 Products 
- 2 Tools 

AR-757H

- 1 Product 
- 2 User Guide 
- 3 Terminal Cables 
- 4 Tools 

Parts Description

- | | | | |
|--|--|--|--|
| a.  Button Head Pozidriv Tapping Screw: M3x10 | b.  Button Head Pozidriv Slotting Screw: 2.5x10 | c.  Flat Head Cap Philips Tapping Screw: 4x19.1 | d.  Flat Head Cap Philips Tapping Screw: 4x38 |
| e.  Security Torx Screw: M3.5x15 | f.  Flat Head Hex Socket Screw: M3x8 | g.  Security Torx Screw: M3x10 | h.  Security Torx Wrenches |

Installation

AR-321H

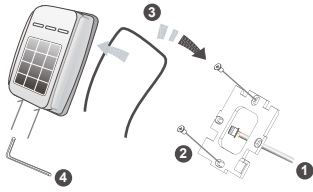

- Pull the cables from the square hole of the mounting plate.
- Use a screwdriver to screw the mounting plate onto the wall.
- Attach the water proof strip to the body, then connect the terminal cables to the body and attach the body to the mounting plate.
- Use the Allen key and screws (accessories supplied) to assemble the body onto the mounting plate.
- Turn on the power, and LED will light and beep will sound.

AR-331H/AR-331H-S

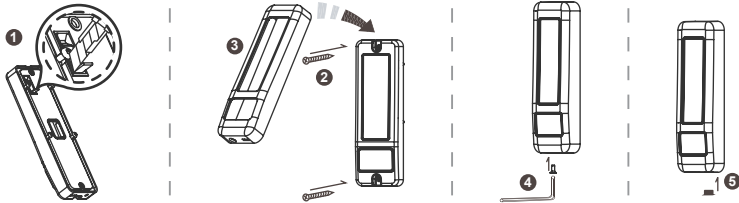

- To cut tamper-resistant column and make it fit the appropriate height for actual installation.
- First, take off the metal casing then screw the controller on the wall.
- Second, put the metal casing back and lock it with security screw.
- Finally, put the Protection plug into the hole.
- Turn on the power, and LED will light and beep will sound.

AR-721H

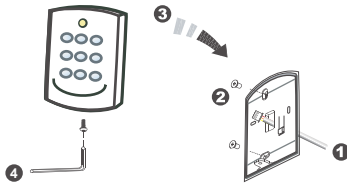

- Pull the cables from the square hole of the mounting plate.
- Use a screwdriver to screw the base onto the wall.
- Connect the terminal cables to the body and attach the body to the mounting plate.
- Assemble the covers with the Allen key and screws (accessories supplied).
- Turn on the power and LED will light and beep will sound.

AR-725H

AR-725H-M

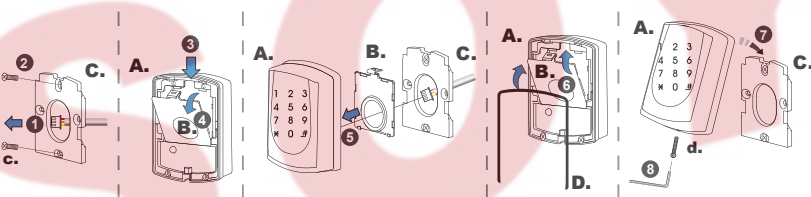

- Pull the cables from the square access hole of the mounting plate C.
- Use a screwdriver to screw the metal plate C onto the wall.
- Take off the plastic mounting plate B from the body A, and pull the cables through the access hole of C and B, then connect to the body A.
- Assemble plate B with the body A, and embed the water proof strip D onto the plastic side frame.
- Assemble the body A onto the mounting plate C with the Allen key and screws (accessories supplied).
- Turn on the power and LED will light and beep will sound.

AR-725H

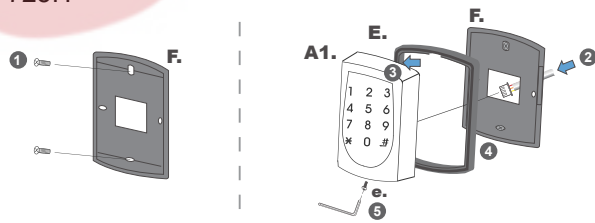

- Use a screwdriver to screw the base F onto the wall.
- Attach the water proof gasket to the body A1, and pull the cables from the square hole of the base F, and connect to the body A1.
- Assemble the body A1 with the base F.
- Screw A1 and F tight with the Allen key and screws (accessories supplied).
- Turn on the power and LED will light and beep will sound.

AR-725X

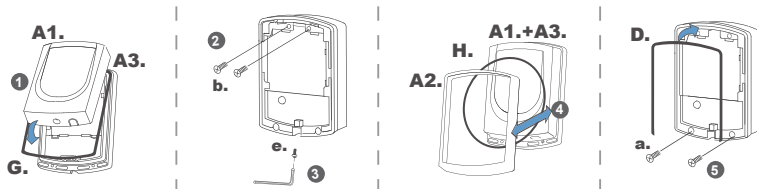

- Put on G, and attach A1 onto the plastic plate A3, and screw it with the Allen key and screws (accessories supplied).
- Put the ring O on the metal frame, and put them together onto the reader A1+A3, and screw them and buckle up the 4 buckles on the back.
- Embed the water proof strip D onto the frame side of the base.
- Following by the install process of AR-725H-M.

AR-757H

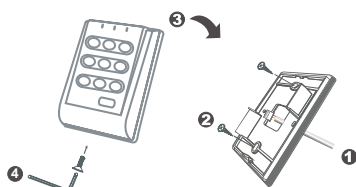

- Pull the cables from the square hole of the mounting plate.
- Use a screwdriver to screw the base onto the wall.
- Connect the terminal cables to the body and attach the body to the mounting plate.
- Assemble the covers with the Allen key and screws (accessories supplied).
- Turn on the power and LED will light and beep will sound.

Notice

- 1.Tubing:** The communication wires and power line should NOT be bound in the same conduit or tubing.
- 2.Wire selection:** Use AWG 22-24 Shielded Twist Pair to avoid star wiring.
- 3.Power supply:** Don't equip controller and lock with the same power supply. The power for controller may be unstable when the lock is activating, that may make the controller malfunction.
The standard installation: Door relay and lock use the same power supply, and controller use independent power supply.

Connector Table

AR-321H

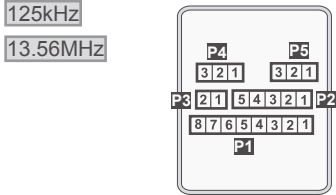

AR-331H/AR-331H-S

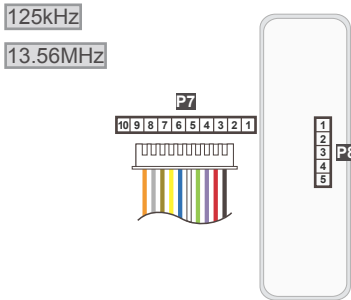

AR-721H

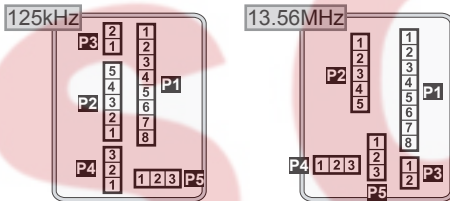

AR-725H

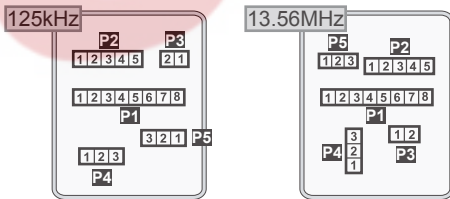

AR-757H

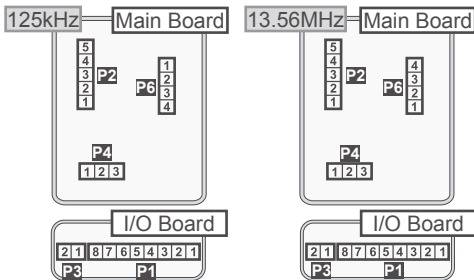

Connectors Comparison

AR-321H	P1	P2	P3	P4	(P5 Optional)
AR-331H	P7	P8			
AR-721H	P1	P2	P3	P4	(P5 Optional)
AR-725H	P1	P2	P3	P4	(P5 Optional)
AR-757H	P1	P2	P3	P4	P6

Cable: P1

Wire Application	Pin	Color	Description
Lock Relay	1	Blue White	(N.O.) DC24V1Amp
	2	Purple White	(N.C.) DC24V1Amp
Common-COM-Point	3	White	(COM) DC24V1Amp
Door contact	4	Orange	Negative Trigger Input
Exit Switch	5	Purple	Negative Trigger Input
Alarm Relay	6	Gray	Low output; Max 12V/100mA (Open Collector)
Power	7	Thick Red	DC Power 12V
	8	Thick Black	DC Power 0V

Cable: P2

Wire Application	Pin	Color	Description
Wiegand	1	Thin Blue	Wiegand DAT:1 Input
	2	Thin Green	Wiegand DAT:0 Input
Beeper	3	Pink	Beeper Output 5V/100mA, Low
LED	4	Brown	LED Green Output 5V/20mA, Max
	5	Yellow	LED Red Output 5V/20mA, Max

Cable: P3

Wire Application	Pin	Color	Description
Networking Module	1	Thick Green	RS-485(B-)
	2	Thick Blue	RS-485(A+)

Cable: P4 Contact Rating: 1A 125VAC/24VDC

Wire Application	Pin	Color	Description
Tamper Switch	1	Red	N.C.
	2	Orange	COM
	3	Yellow	N.O.

※After S/N: 0706-XXXXXX

Cable: P5 (Optional)

Wire Application	Pin	Color	Description
3-PIN Connector	1	Black	GND.
	2	White	Duress
	3	Purple	Arming/ Security trigger signal

Cable: P6

Wire Application	Pin	Color	Description
Door bell	1	Brown White	BE Output
Arming	2	Red White	AR Output/ Security trigger signal Output
Duress	3	Yellow White	DU Output/ TTL out
LED indicator	4	Green White	Hi input/ Green light brighten

Cable: P7 (Directly connected at the Access controller)

Wire Application	Pin	Color	Description
Power	1	Black	DC Power 0V
	2	Red	DC Power 12V
Exit Switch	3	Purple	Negative Trigger Input
Networking Module	4	Green	RS-485(B-)
Lock Relay	5	White	Low output; Max 12V/100mA (Open Collector)/ Security trigger signal Output
	6	Blue	RS-485(A+)
Tamper Switch	7	Yellow	N.O.
	8	Brown	COM
Alarm Relay	9	Gray	Low output; Max 12V/100mA (Open Collector)
Door contact	10	Orange	Negative Trigger Input

Cable: P8 (for external WG Reader)

Wire Application	Pin	Color	Description
LED	1	Brown	LED Green Output 5V/20mA, Max
	2	Yellow	LED Red Output 5V/20mA, Max
Beeper	3	White	Beeper Output 5V/100mA, Low
Wiegand	4	Blue	Wiegand DAT:1 Input
	5	Green	Wiegand DAT:0 Input

Wiring Diagram

Connect to Magnet Lock or Electric Bolt

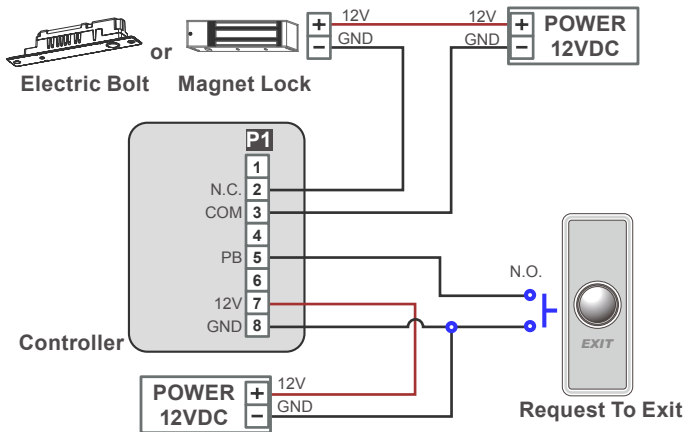

Connect to Electric Strike

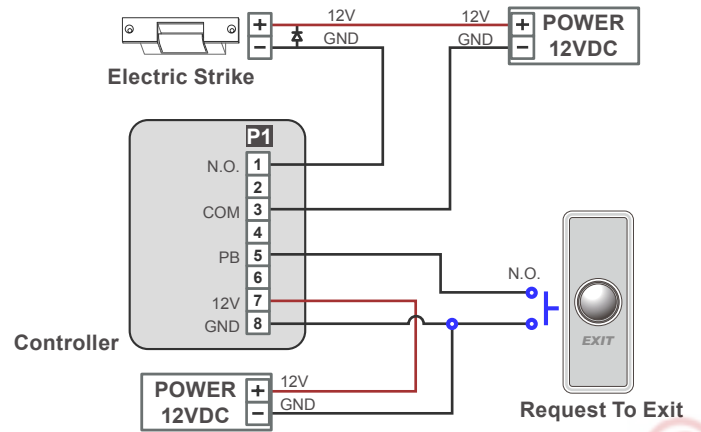

Connect to Reader

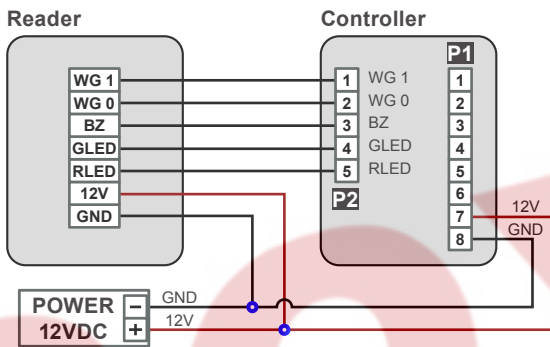

Connect to Door Sensor

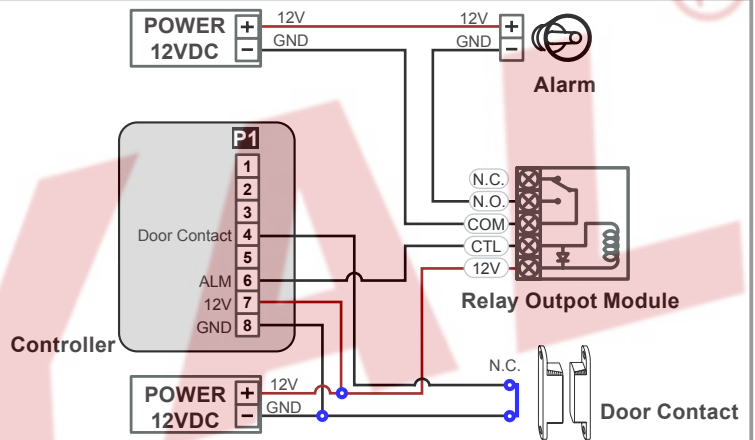

Strengthen security with AR-721RB

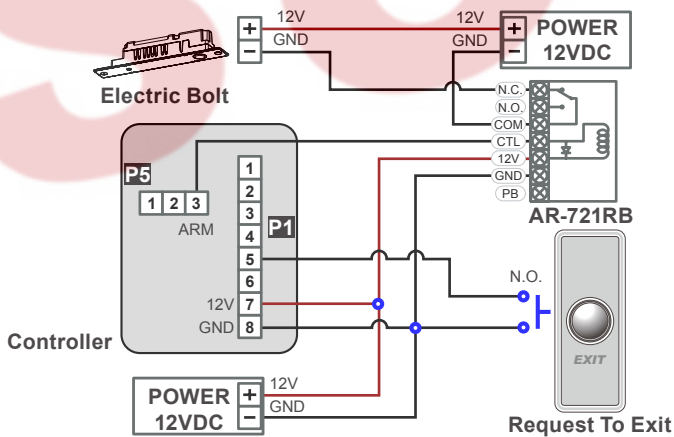

Connect to Networking

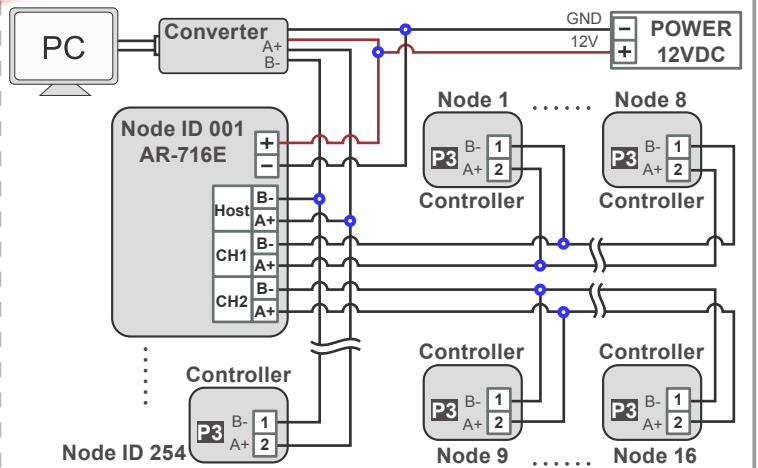

- ※ 1.Enable the security trigger signal: Please refer to the 34 * DDD #
- 2.Disable the door open button input. (Please refer to the 20 * DDD #) of function default value.)

Connect to Access Control for P7

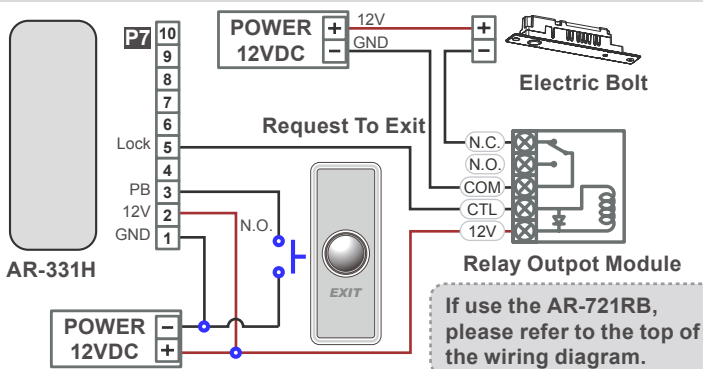

Connect to arming tools for P7

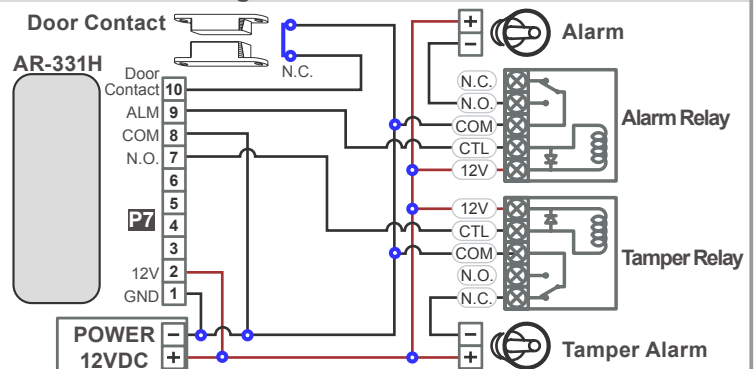

Connect to Reader for P8

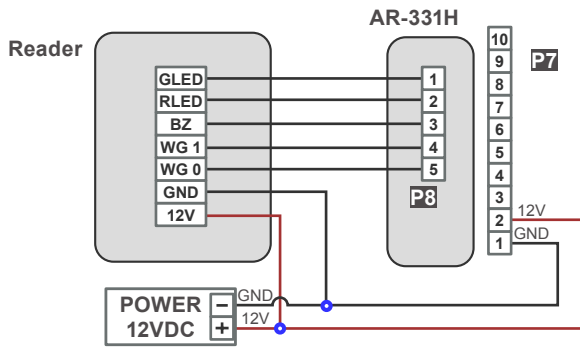

Connect to Networking for P7

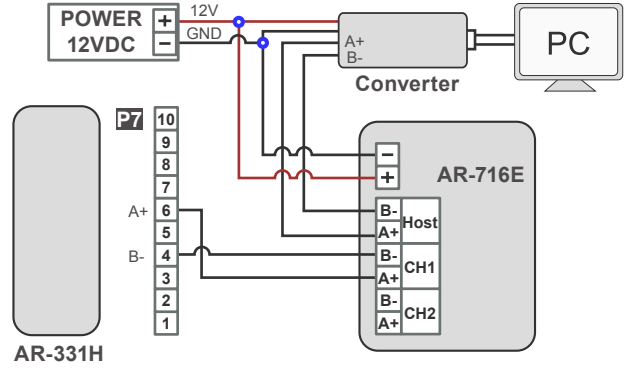

External WG keyboard

※ If you want to program system on AR-331H-S directly, please order WG keyboard then install it according to the following pattern.

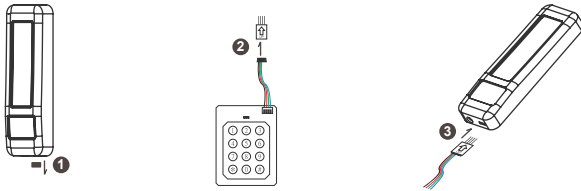

- Remove the Protection plug that in the bottom right.
(※ Do not lose protection plug or it will affect the protection level.)
- WG Keyboard cable will be connected to the pin board.
- WG Keyboard connected to the controller from the bottom right of the hole.
- When you finish programming system, please put protection plug back to the controller.

AR-331H Interaction Area

331HB(125kHz)

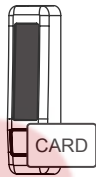

※331HB touch card-area for interaction.

- Metal controller's Induction scope is smaller than others ,and EM(331HB) / MIFARE(331HD) is different. Refer to the picture.

331HD(13.56MHz)



※331HD touch keyboard area for interaction.

Adding and Deleting Tag

Mode4/Mode8

• Add Single Tag or Random tags

Input *123456# (or Master Code) → 19*UUUUU*00001# → Present the tag(s) with Controller (single tag or random numbered cards one by one) → Done
[e.g.] 2 readom cards with user addresses No. 100 and No. 101:

Access programming mode → 19*00100*00001# → Present the tags one by one → Done

• Add the Sequential tags

Input *123456# (or Master Code) → 19*UUUUU*QQQQ# → Present the tags (Present the tag with the lowest number first.) → OK

[e.g.] User Address NO.101 to NO.120 have 20 pcs of sequential tags:(62312~62332):

Access programming mode → 19*00101*00120# → Close Tag into RF Area(only use the tag NO.62312) → OK

• Delete a Single Tag

Input *123456# (or Master Code) → 10*SSSS9EEEE#

[e.g.] Delete User Address: 00058

Access programming mode → 10*00058900058#

• Delete a batch of Tags

Input *123456# (or Master Code) → 10*SSSS9EEEE#

[e.g.] Delete User Address: 00101~00245

Access programming mode → 10*00101900245#

• Delete All Tags

Input *123456# (or Master Code) → 29*29*#

Tag Information

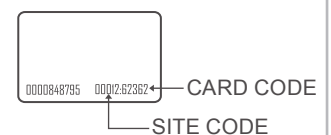

Mode6 ※At this mode, User Address = Card Code

• Add Tags

Input *123456# (or Master Code) → 11*SSSS*EEEE# → OK

[e.g.] Add User Address: 00100~01254

Access programming mode → 11*00100*01254# → OK

• Delete Tags

Input *123456# (or Master Code) → 10*SSSS*(or 9)EEEE# → OK

[e.g.] Delete a tag with card code 62362

Access programming mode → 10*62362*62362# → OK

• Delete All Tags

Input *123456# (or Master Code) → 29*29*#

Operation process

A. Enter/ Exit Program Mode

- Enter the program mode

Input *123456# or *PPPPPP#

[e.g.] The Default Value= 123456, if already changed the Master Code= 876112, input *876112# → program mode accessed

- Exit the program mode

Input * #

- Master Code modification

Access programming mode → 09 *PPPPPPRRRRR# [Input the 6-digit new master code twice.]

[e.g.] Set the Master code to be 876112, input * 123456# → 09 * 876112876112 #

B. Chang the Node ID of Controller

Access programming mode → 00 *NNN# [Node ID: 001~254]

C. Set up M4/M6/M8

Access programming mode → 04 *N# [N=4/6/8]

D. Set up the password

- M4/M8: Individual pass code

Card or PIN: Access programming mode → 12 *UUUUU *PPPP# [e.g. User address: 00001 and pass code: 1234, input 12 * 00001 * 1234 #]

Card and PIN: Access programming mode → 13 *UUUUU *PPPP# [e.g. User address: 00001 and pass code: 1234, input 13 * 00001 * 1234 #]

- M6: Public pass word

Card or PIN: Access programming mode → 15 *PPPP# [Input 4-digit pass code, default value: 4321]

Card and PIN: Access programming mode → 17 *PPPP# [Input 4-digit pass code, default value: 1234; PPPP=0000: change into Card Only]

E. Dual Door Control(M4/M8)

Controller with an reader to do the "Dual Door Control".

Access programming mode → 28 *064# [064= Dual Door Control]

F. Anti-pass-back(M4/M8)

Usually, anti-pass-back is commonly applied to parking areas in order to prevent from multi-entry with one card at a time, or to situations need access and exit monitor.

- Enable controller

Access programming mode → 20 *DDD# [128= Anti-pass-back(0=Disable; 1=Enable)/ 064=Access/Exit(0=Exit; 1=Access).]

[e.g.] Enable Anti-pass-back, and set to Exit door= (128 x 1) + (064 x 0) = 128

Access programming mode → 20 *128# (Please refer to function default value for details.)

- Enable card

Access programming mode → 26 *SSSS *EEEE *N#

[SSSS= User address start; EEEEE= User address end; N=0(control)/ 1(Not control)/ 2(reset)]

[e.g.] User address from 00152 to 00684 enable the anti-pass-back function: 26 * 00152 * 00684 * 0 #

[e.g.] No. 154 enable the anti-pass-back, and induction into the door has not been induced to leave. When he represent into the door will become invalid , then he needs to set the reset. Access programming mode → 26 *00154 * 00154 * 2 # → Reset

G. Auto Open Time Zone

Door will keep open after the first flashing card. There are 2 time zones supported when Stand-Alone, and 63 time zones when it connect to AR-716E.

- Enable/Disable auto open zone

Access programming mode → 20 *004# [004= enable Auto-Open Time Zone; 000= disable Auto-Open Time Zone]

- Enable/Disable auto open door without presenting card

Access programming mode → 24 *001# [001= enable Auto-Open Time Zone; 000= disable Auto-Open Time Zone]

- Set up open time

Access programming mode → 08 *N *HHMMhhmm *7123456H#

N: 2 sets of auto-open zone (N=0=1st set; N=1=2nd set)

HHMMhhmm=Starting time to ending time (e.g. 08301200=08:30 to 12:00)

7123456H= 7 days of week + Holiday (Sun/Mon/Tue/Wed/Thu/Fri/Sat) (H= 0: disable; 1: enable); Holidays establish by the software.

[e.g.] To set the second time zone as 9:30 AM to 4:20 PM, Monday, Wednesday and Friday: 08 *1 *09301612 * 01010100 # → Done

H. Lift control

Connect with **AR-401RO16B** to control floors which the user will be able to access.

- Enable

Access programming mode → 24 *002# [002= enable lift control]

- Single floor

Access programming mode → 27 *UUUUU *FF#

UUUU=User Address FF=Floor number (01~32 floor)

[e.g.] User address NO. 45, allow to access the 24th floor: 27 * 00045 * 24 #

- Multi floors

Access programming mode → 21 *UUUUU *S * FFFFFFFF#

[UUUUU=User address S: 4 sets of lift control (Input: 0~3) FFFFFFFF: 8 floors setting (F=0=Disable, F=1=Enable)]

[e.g.] User address NO. 168, only to the 6th and the 20th floor:

Access programming mode → 21 * 00168 * 0 * 0010000 # → 21 * 00168 * 2 * 00001000 #

Please refer to below floor chart

Set	Floor/ Stop							
	F	F	F	F	F	F	F	F
0	8	7	6	5	4	3	2	1
1	16	15	14	13	12	11	10	9
2	24	23	22	21	20	19	18	17
3	32	31	30	29	28	27	26	25

I. Setting Up the Arming

• Alarm conditions:

1. Arming is enabled
2. Alarm system connected

• Application:

1. **Door open too long:** Door is open longer than door relay time plus door close time.
2. **Force open** (Opened without a valid user card): Access by force or illegal procedure.
3. **Door position abnormal:** Arming is enabled and the power is suddenly off then on.

• Enable/Disable Arming status (for M4/M8; Factory default armingcode is: 1234) :

Standby Mode	
After door open	Do not open the door
The normal procedure to open door → Input 4 digit arming code → #	* → Input 4 digit arming code → Present valid card
Enter Program Mode	
Enable: Access programming mode → * * #	Disable: Access programming mode → * #

※ [The normal procedure to open door] can refer to [Access Mode].

Function Default Value

AR-321H / AR-331H / AR-721H / AR-725H / AR-757H

20 * DDD #	※Default Value			
Function	Selection		Value	Application
Attendance	※0: Yes	1: No	001	Networking
Auto Re-lock	※0: Disable	1: Enable	002	Networking/Stand-Alone
Auto Open	※0: Disable	1: Enable	004	Networking/Stand-Alone
Door open button input	0: Disable	※1: Enable	016	Networking/Stand-Alone
Master Controller of Network	※0: Slave	1: Mater	032	Networking
Access/Exit	※0: Exit	1: Access	064	Networking
Anti-pass-back	※0: Disable	1: Enable	128	Networking

Selection= 0(none value)/ 1(1 x each value)
[e.g.] DDD value of Enable "Auto Open" + "Exit by Push Button" + "Anti-pass-back" =004+016+128=148;
As a result of that, the command will be 20 * 148 #.

28 * DDD #	※Default Value			
Function	Selection		Value	Application
Dual Door Control	※0: Disable	1: Enable	064	Networking/Stand-Alone
Force Open Alarm Output	※0: Disable	1: Enable	128	Networking/Stand-Alone

AR-321H / AR-331H / AR-721H / AR-725H

24 * DDD #	※Default Value			
Function	Selection		Value	Application
Auto-open door without cards at auto open zone	※0: Disable	1: Enable	001	Networking/Stand-Alone
Alarm Output/ Lift Control	※0: Alarm Output	1: Lift Control	002	Networking/Stand-Alone
Stop Alarm by door close or by push button	0: None	※1: Yes	064	Networking/Stand-Alone
Door bell	※0: Disable	1: Enable	128	Networking/Stand-Alone

AR-757H

24 * DDD #	※Default Value			
Function	Selection		Value	Application
Auto-open door without cards at auto open zone	※0: Disable	1: Enable	001	Networking/Stand-Alone
Lift Control/ Duress Function	※0: Lift Control	1: Duress	002	Networking/Stand-Alone
Stop Alarm by door open or door close button	0: None	※1: Yes	064	Networking/Stand-Alone

Mode4 / Mode6 / Mode8

Mode	Networking/ Stand-Alone	User Capacity	Access Mode	Auto-show Duty time	Event log Capacity	120 Holidays	Anti force	Time Zone	Lift Control	Anti-pass-back
M4	Networking/ Stand-Alone	1,024 (721H/757H) 3,000 (321H/331H/725H)	1.Card only 2.Card and PIN (4-digit PIN)+ # 3.Card or User address (5-digit) + Individual PIN (4-digit individual PIN) + #	Yes	1,200(721H) 1,500 (321H/331H/725H) 3,000(757H)	Yes	Yes	11	32	Yes
M6	Stand-Alone	65,535	1.Card only 2.Card and PIN (4-digit public PIN=Arming PWD)+ # 3.Card or PIN (4-digit public PIN=Duress code)	No	No	No	No	No	No	No
M8	Networking/ Stand-Alone	1,024 (721H/757H) 3,000 (321H/331H/725H)	1.Card only 2.Card and PIN (4-digit individual PIN)+ # 3.Card or PIN (4-digit individual PIN)	Yes	1,200(721H) 1,500 (321H/331H/725H) 3,000(757H)	Yes	Yes	11	32	Yes

※ **Mode 6**, the number of users up to 65535, since it reads **CARD CODE**(5 digits) only, unlike that Mode4/Mode8 read **SITE CODE** and **CARD CODE**(10 digits).

Factory Reset by its commands

• When the device is stand-alone (not networking)

Access programming mode → 20 * 016 # → 24 * 064 # → 26 * 00000 * 01023 * 1 # → 28 * 000 # → 29 * 29 * #

※Note: After the Master Code is changed, factory reset doesn't restore the Master Code back to 123456.

Access Controller

Command List

Function	Command	Description	Mode
Entering programming mode	* PPPPPP #	PPPPPP=Master Code, default value=123456	M4/M6/M8
Exiting programming mode	* #		M4/M6/M8
Exiting programming mode and enabling arming status	* * #		M4/M8
Node ID setting (Connecting to 716E)	00 * NNN #	NNN=Node ID, range: 001~254	M4/M8
Node ID setting (Connecting to PC directly without via 716E)	00 * NNN * VVV * nnn #	NNN=Node ID of Access Controller, VVV=Virtual 716E Node ID, nnn=Door number; range:001~254	M4/M8
Mifare tag / card format (Optional)	01 * N #	N: 0=ISO14443A; 1=ISO14443B; 2=ISO15693; 3=I Code1; 4=I Code2 PS.1. Please select the compliance,first. 2. Make sure reader and card using the same compliance.	M4/M8
Door relay time setting	02 * TTT #	TTT=Door relay time 000= Output constantly 001~600=1~600 sec. 601~609=0.1~0.9 sec.	M4/M6/M8
Alarm relay time setting	03 * TTT #	TTT=Alarm relay time 000= Output constantly 001~600=1~600 sec.	M4/M6/M8
Control mode setting	04 * N #	N=Mode 4=Mode4 : 6=Mode6 : 8=Mode8	M4/M6/M8
Arming delay time setting	05 * TTT #	TTT=Arming delay time 001~600=1~600 sec.	M4/M6/M8
Alarm delay time setting	06 * TTT #	TTT=Alarm delay time 001~600=1~600 sec.	M4/M6/M8
Master card setting	07 * SSSSS * EEEEE #	SSSSS-EEEEEE=00000-01023 (00000-03000 for AR-725H); SSSSS=Starting user address; EEEEE=Ending user address	M4/M8
Auto-open time zone setting	08 * N * HHMMhmm * 7123456H #	N= 0(1st time zone) / 1(2nd time zone) HHMM= Starting time; hmmm= ending time (i.e.: 08301200=08:30 to 12:00) 7123456H= 7 days of week (Sun/Mon/Tue/Wed/Thu/Fri/Sat)+ Holiday (H= 0: disable; 1: enable); Holidays establish by the software.	M4/M6/M8
Master code setting	09 * PPPPPRRRRRR #	PPPPPP=New master code RRRRRR=Repeat the new master code	M4/M6/M8
Suspend / Delete tag	10 * SSSSS * EEEEE # 10 * SSSSS 9 EEEEE #	* =Suspend 9 =Delete; SSSSS=Starting user address, EEEEE=Ending user address	M4/M6/M8
Set a sequence of cards as "read and access"	11 * SSSSS * EEEEE #	SSSSS=Starting card number EEEEEE=Ending card number	M6
Active the suspended cards	11 * SSSSS * EEEEE #	SSSSS=Starting user address EEEEEE=Ending user address	M4/M8
Set the cards as Card mode OR PIN mode by user address	12 * UUUUU * PPPP #	Access mode: Card or PIN ; UUUUU=user address; PPPP=4-digit pass code 0001~9999	M4/M8
Set the cards as Card AND PIN mode by user address	13 * UUUUU * PPPP #	Access mode: Card and PIN ; UUUUU=user address; PPPP=4-digit pass code 0001~9999	M4/M8
Arming output time setting	14 * TTT #	TTT=Arming output time; 000~250=0~2.5 sec.	M4/M8
M4/M8: Duress code setting	15 * PPPP #	PPPP=4-digit pass code (default value=4321)	M4/M6/M8
M6: Public PIN setting (Card or PIN)	16 * UUUUU * SSSSSCCCC #	UUUUU= User address; SSSSS=5-digit site code; CCCCC=5-digit card code	M4/M8
M4/M8: Arming pass code setting	17 * PPPP #	PPPP=4-digit pass code (default value=1234; disable Arming PWD=0000)	M4/M6/M8
M6: Public PIN setting (Card and PIN)	18 * TTT #	PS. Arming PWD code will be unavailable and become a public PIN at access mode "Card PIN" and of M6 TTT=Door open waiting time: 001~600=1~600 sec.; default value: 15 sec.	M4/M6/M8
Set the card by induction(M4/M8)	19 * UUUUU * QQQQ #	UUUUU=User address; QQQQ=Card quantity(0001=Continuously inducting)	M4/M8
Reader additional setting	20 * DDD #	Please refer to function default value for details.	M4/M6/M8
Lift control setting: multi-doors	21 * UUUUU * S * FFFFFFFF #	UUUUU=User address, S=4 sets of lift control(0~3); FFFFFFFF=8 assigned floor (F=0: Disable, 1: Enable)	M4/M8
Add/Delete tag by induction (M6 only)	22 * N #	N=0(Delete tag); N=1(Add tag)	M6
AR-401RO16 Lift Relay Activated TM	23 * NNN * TTT #	NNN=site number, TTT= relay time: 000~600=1~600 sec.	M4/M8
Controller parameter setting	24 * DDD #	Please refer to function default value for details.	M4/M6/M8
Controller time clock setting	25 * YMMDDHHmmss #	YMMDDHHmmss: Year/ Month/ Day/ Hour/ Min./ Sec.	M4/M6/M8
Anti-pass-back (Enable user)	26 * SSSSS * EEEEE * N #	SSSSS=Starting user address; EEEEE=Ending user address; N=0/Enable; N=1/Disable; N=2/Initial	M4/M8
Single floor setting	27 * UUUUU * FF #	UUUUU=User Address; FF=Floor (01~32 floor)	M4/M8
Dual door control/ Active or inactive arming for force open	28 * DDD #	Please refer to function default value for details.	M4/M6/M8
Delete all tags	29 * 29 * #		M4/M6/M8
Enable the security trigger signal (with AR-721RB)	34 * 128 # (321H/721H/725H/757H) 34 * 064 # (331H) 34 * 000 # (Disable)	To Change the "Arming" (in 25) become the security trigger signal, when controller is connected with AR-721RB.	M4/M6/M8